

IP Speed Dome Hardware Installation Guide

Ver. 060520

Table of Contents

1	INTRODUCTION.....	1-1
1.1	Package Contents	1-1
1.2	Features and Benefits.....	1-2
1.3	Safety precautions.....	1-3
1.4	Warning indications for use.....	1-3
1.5	Environmental requirements.....	1-3
1.6	Precautions on installation.....	1-4
2	H/W Installation Procedure	2-6
2.1	Connections	2-6
2.1.1	Indoor connections	2-6
2.1.2	Outdoor connections.....	2-7
2.2	Speed dome set up.....	2-9
2.2.1	Setup camera ID, baud rate and protocol.....	2-9
2.3	Indoor H/W Installation Procedures.....	2-11
2.3.1	Indoor installation.....	2-11
2.4	Outdoor H/W Installation Procedures.....	2-13
2.4.1	Understand Outdoor applications.....	2-13
2.4.2	Install the mount.....	2-14
2.4.3	Connect the housing to the mount.....	2-16
2.5	Detailed dimensions	2-19
2.5.1	Outdoor Housing	2-19
2.5.2	Outdoor Wall mount.....	2-20
2.5.3	Outdoor Ceiling mount.....	2-21
2.5.4	Outdoor Corner mount	2-22
2.5.5	Outdoor Pole mount	2-23
3	Appendix.....	3-24
3.1	Camera ID Sep up.....	3-24

1

INTRODUCTION

1.1 Package Contents

Indoor

Outdoor



Power Core (for Indoor)

Software CD



Adapter (for Indoor)



1.2 Features and Benefits

- **MPEG-4 compression gives a high resolution image quality**
The IP speed dome offers an optimal combination of network, digital, and optical technology. The IP Speed Dome adopts MPEG-4 ASP compliant compression technology which compress video analog into video streaming while maintaining resolution up to full-D1, 30 fps. Building in with LAN and WAN ports, the IP Speed Dome applies QoS (Quality of Service) technology to fully utilize the network bandwidth. Meanwhile, IP Speed Dome also supports multicast video streaming technologies to fulfill almost unlimited on-line video requests.
- **Remote control from any place at any time**
The IP Speed Dome Series adopts SoC base embedded system and web server which enables remote control of the camera. Through bundled AP, you can pan/tilt/zoom the camera, set up motion detection to a specified area, perform tour monitoring, set up different video resolutions, etc. In addition, features such as tour surveillance, alarm, 32 presets, further enhance the usefulness of IP Speed Dome Series to make your remote surveillance more flexible and more responsive to different situations or environments.
- **High quality and reliability in both optics and mechanism**
With a cleverly designed pan/tilt mechanism and an industrial-grade slip ring, the IP speed dome accurate auto zoom system, and powerful 352X zoom capability.

1.3 Safety precautions

1. Select a proper location and use safe hoist for installing speed dome cameras.
2. Confirm that the hoist is capable of lifting to the installation position.
3. Proper protective measures must be provided in the hoist, for protecting engineering staffs.
4. Confirm that power supply is 110V/220V. Ensure safety precautions for preventing electric shock.

1.4 Warning indications for use

1. Local electrical appliance regulations must be observed for using this product.
2. The outdoor model uses AC24V, while the indoor model uses DC12V. For safety of use, do not use any power supply other than that specified.
3. For the safety of the engineering staffs, apply power only upon completion of installation.

1.5 Environmental requirements

1. **Environmental requirements for indoor type speed dome cameras:**
 - Environment temperature: -10°C to +40°C
 - Environment humidity: <90%
 - Power supply: DC12V, 2000mA, 50/60Hz
2. **Environmental requirements for outdoor type speed dome cameras:**
 - Environment temperature: -40°C to +50°C
 - Environment humidity: <90%
 - Power supply: AC24V, 2.0A, 50/60Hz

1.6 Precautions on installation

1. Basic requirements for installation

- Follow local regulations about installation safety request.
- Check out if accessories are complete. Optional accessories are required for different installation sites. Please contact your local distributors for proper installation accessories, so that the camera could be installed safely without causing danger.

2. Check if the installation location is of sufficient height.

3. Check if the installation location is strong enough for supporting cameras. Make sure installation spots (ceiling or wall) is of sufficient strength to support the camera and bracket without immediate danger of falling.

4. Cable standards

Coaxial cable for image signal:

Select proper cable length for your installation distance. Recommended spec. is as follows:

- RG59/U: 750ft (230 meters)
- RG6/U: 1000ft (305 meters)
- RG11/U: 1500ft (457 meters)

RS485 cable

Please comply with RS485 wiring standards and select proper RS485 cable. Improper cable may result in RS485 communication transmission error, which may cause speed dome cameras to react incorrectly. Please pay much attention to this prior to installation.

When thinner or lower anti-interference RS485 cable is used for connecting the camera, the maximum transmission distance may be shortened and vice versa.

Details will be given in the follow-up sections.

5. Setting of Camera Position Code

Setup your camera ID address and communication protocol prior to installation. In order to make a new setting valid, please shut down the power before re-setting.

6. Self Test of Camera

The camera is available with the following self test. Carry them out prior to installation. After connecting power, speed dome camera will

turn 90 degrees down vertically, then start horizontal scanning. This will last for 20-30 seconds. Speed dome camera will then stop at the Preset Position 1. On completion of these, the speed dome camera is in normal condition.

7. Please keep the original packaging

After unpacking the camera, take good care of the original packaging. In case any problem occurred, it can be used to re-pack cameras for returning to the local distributor or manufacturer for repair.

8. Remove protection materials before supplying power to the camera, so as to prevent it from faulty operation or causing mechanical errors. See the following illustration.

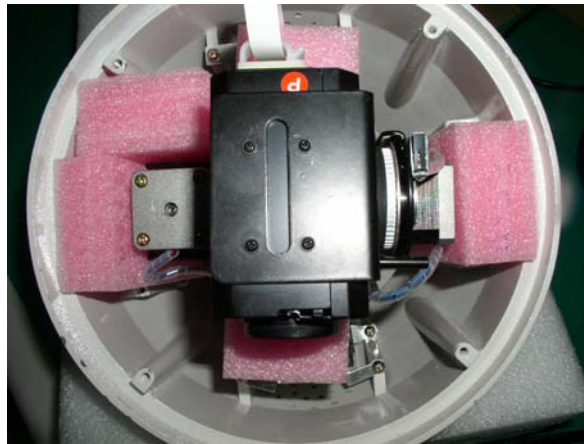

9. This product is normally installed in an elevated position. Installation work should comply with local safe regulations.

10. Proper safety precautions and protective measures shall be taken for installing the camera.

11. For the personnel safety sake, carry out electrification and product test only after completion of installation work.

2

H/W Installation Procedure

2.1 Connections

Indoor IP speed dome connection is different from the outdoor IP speed dome. Follow the description below to connect to respective apparatus.

2.1.1 Indoor connections

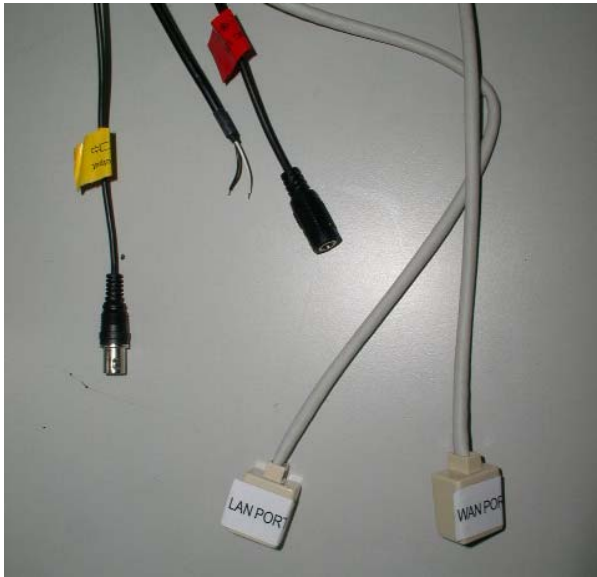

1. Analog Video-out connector

Connect it to the video-in port of respective apparatus. The signal is 75Ω Composite Video Signal.

2. DC jack

Connect this DC jack to the power supply of 12VDC, 1.0A input.

3. LAN port

The video server connects to the LAN (local area network) via a standard RJ45 connector. Supporting NWAY, this video server can auto detect the speed of local network segment (10Base-T/100Base-TX Ethernet).

4. WAN port

The video server connects to the WAN (wide area network) via a standard

RJ45 connector. Supporting NWAY, this video server can auto detect the speed of local network segment (10Base-T/100Base-TX Ethernet). The WAN port is for FTTH and connects to a xDSL or cable modem.

5. RS-485

This connection is reserved for local analog control panel. You don't have to connect it in normal conditions.

2.1.2 Outdoor connections

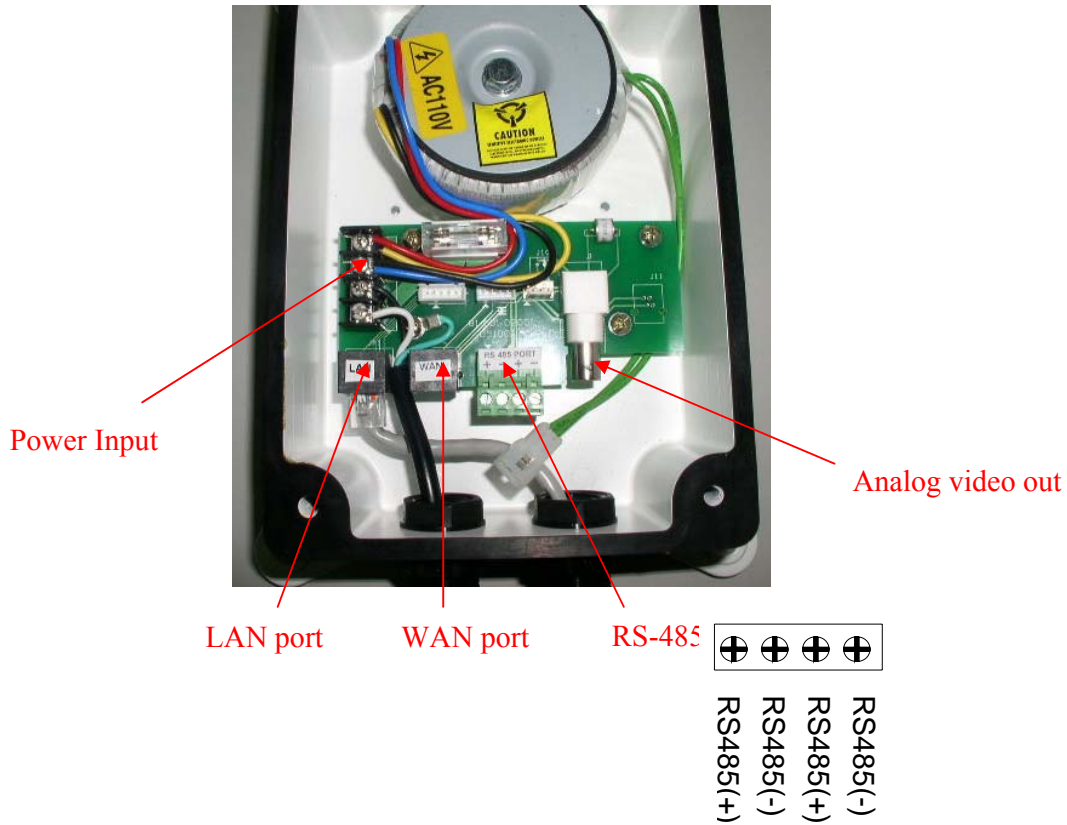

1. Analog Video-out connector

Connect it to the video-in port of respective apparatus. The signal is 75Ω Composite Video Signal.

2. Power input

Connect this jack to the power supply of 110VAC or 230VAC according to the product you bought.

3. LAN port

The video server connects to the LAN (local area network) via a standard

RJ45 connector. Supporting NWAY, this video server can auto detect the speed of local network segment (10Base-T/100Base-TX Ethernet).

4. WAN port

The video server connects to the WAN (wide area network) via a standard RJ45 connector. Supporting NWAY, this video server can auto detect the speed of local network segment (10Base-T/100Base-TX Ethernet). The WAN port is for FTTH and connects to a xDSL or cable modem.

5. RS-485

This connection is reserved for local analog control panel. You don't have to connect it in normal conditions.

2.2 Speed dome set up

Follow the description below setup IP speed dome's hardware camera ID, baud rate and protocol.

Speed dome setup	Video platform setup	AP (IP Video Control Center) setup
Camera ID, baud rate and protocol setting in these 3 item should be the same for PTZ control function to work.		

2.2.1 Setup camera ID, baud rate and protocol

Loosen the four screws and de-attached the dome cover from the housing. Follow the tables below to setup each respective parameter. A 10-position DIP SWITCH is furnished on the camera control board. SW1~ SW8 are for ID address setting and SW9/SW10 are for protocol setting. Respective setting is illustrated in the following table:

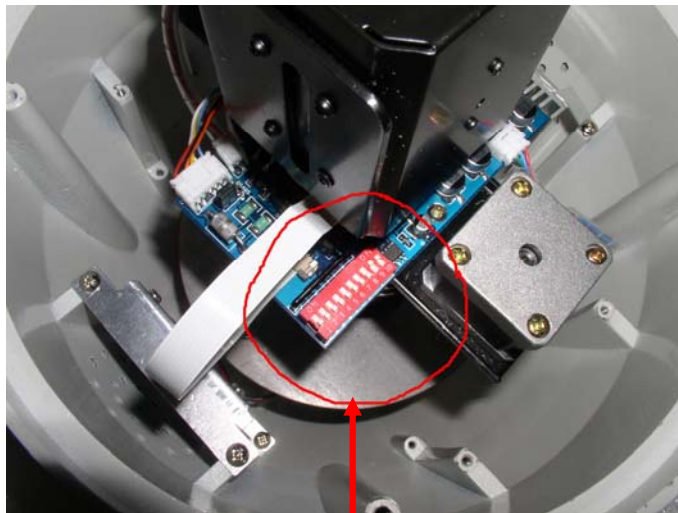

Address ID								Protocol/ Baud Rate	
1	2	3	4	5	6	7	8	9	10

Setting of camera ID Address and
Communication Protocol

- **Protocol and baud rate switch**

	SW9	SW10
PELCO D-2400	OFF	OFF
PELCO P-4800	ON	OFF
PELCO P-9600	OFF	ON
EYEVIEW (Recommended)	ON	ON

- **Camera ID address setting**

Please refer to the Appendix. A “Camera hardware ID setup”

2.3 Indoor H/W Installation Procedures

2.3.1 Indoor installation

1. Installing the camera:

Take out the camera upper casing, as shown below:

Wall mount

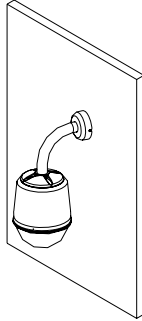

Pendent mount

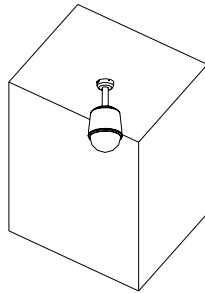

2. Wiring

After completion of the above works, connect the wires for video/DC12V Power Input/ LAN/WAN according to the instructions shown as following figure:

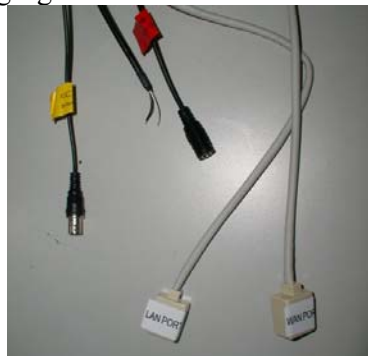

3. Electrification test
 - Before connecting the power, make a final check to confirm correct wiring.
 - After electrification, the camera will undertake an automatic self-test. This routine consists of vertical scanning following by horizontal scanning. Then the camera automatically swings to Position 1. This concludes the initialization of self-test.
4. Install the dome cover

Finishing all the above, the transparent dome cover can be installed. Make sure the screws are driven tightly.

2.4 Outdoor H/W Installation Procedures

There are 4 kinds of outdoor application. And each of them requires two steps to install the outdoor IP speed dome. Please refer to the picture below to understand each application type.

Then follow the procedure below to install it.

2.4.1 Understand Outdoor applications

- **Outdoor Wall mount**

Outdoor Housing + outdoor Wall mount

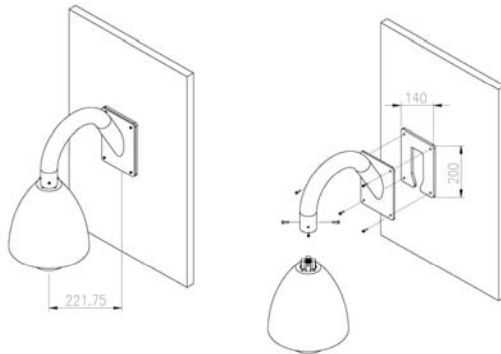

- **Outdoor Ceiling mount**

Outdoor Housing + outdoor Ceiling mount

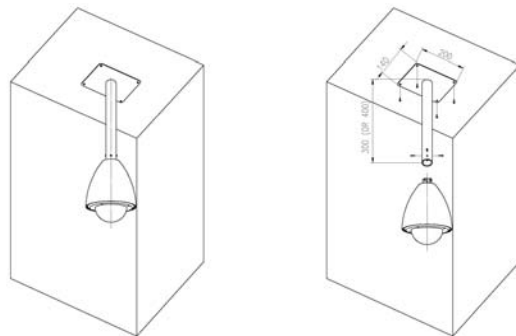

- **Outdoor Corner mount**

Outdoor Housing + outdoor Wall mount + outdoor Corner bracket

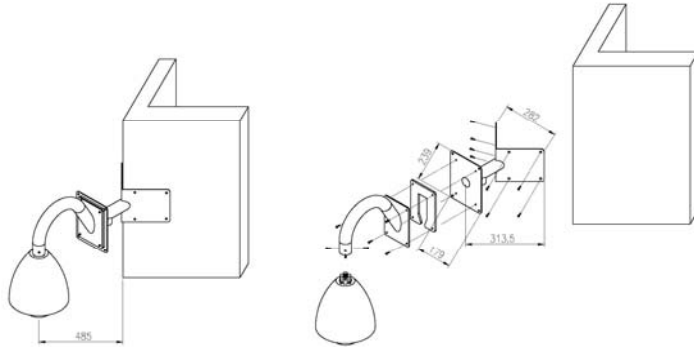

- **Outdoor Pole mount**

Outdoor Housing + outdoor Wall mount + outdoor Pole bracket

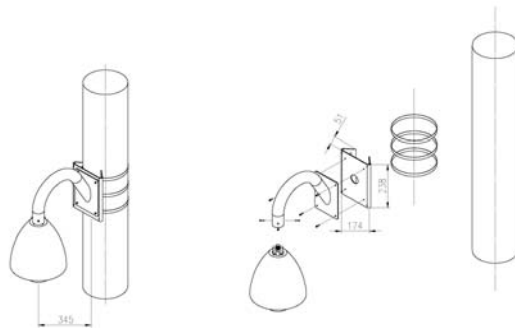

2.4.2 Install the mount

The mounting wall must be strong enough for holding the camera. Minimum loading capacity should be at least 35 kg or above, for prevention of fall and personal injury.

- Mark the 4 mounting hole centers according to the mount base plate, as

shown below:

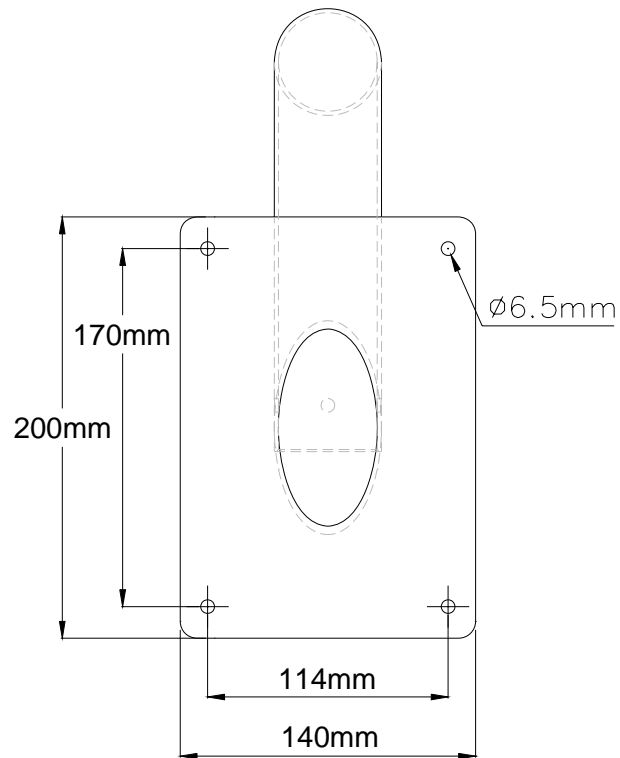

- Drill 4 holes $\varnothing 6.5\text{mm}$:
- Use the 4 screws provided to fix the mount on the wall

2.4.3 Connect the housing to the mount

- Insert the cable from the housing through the hole. There's some lubricating oil inside the tube, thus the cable would have some oil on it once inserted through the Tube.



- Then take out M6 screws and hexagonal wrench provided within the package and fasten the 4 screws as picture below.



- Connect the housing cable to the board in the junction box

Start to connect



Connect done

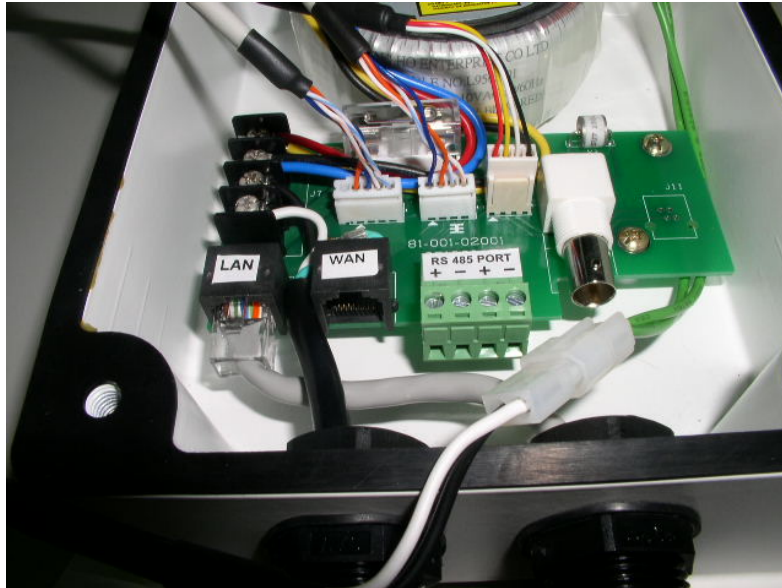

- Connect the junction box to respective apparatus.
Please refer to Page 2-17 for how to connect.

2.5 Detailed dimensions

2.5.1 Outdoor Housing

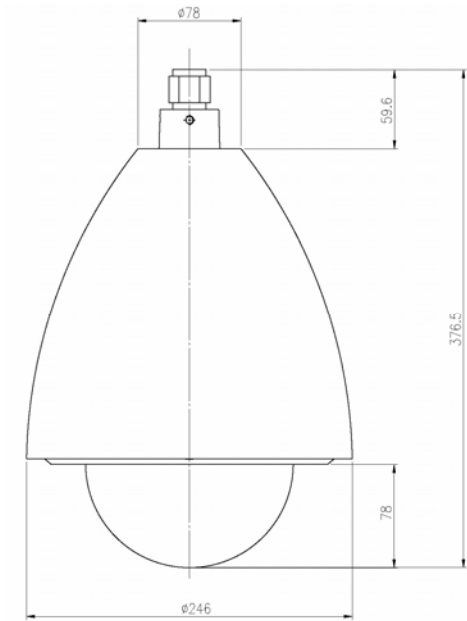

2.5.2 Outdoor Wall mount

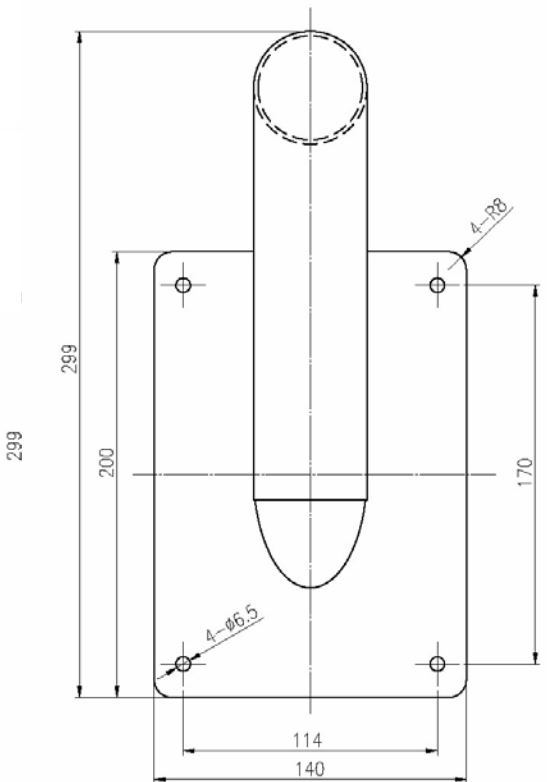
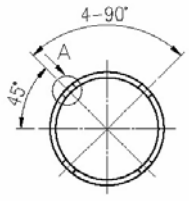
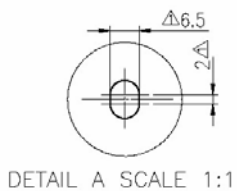
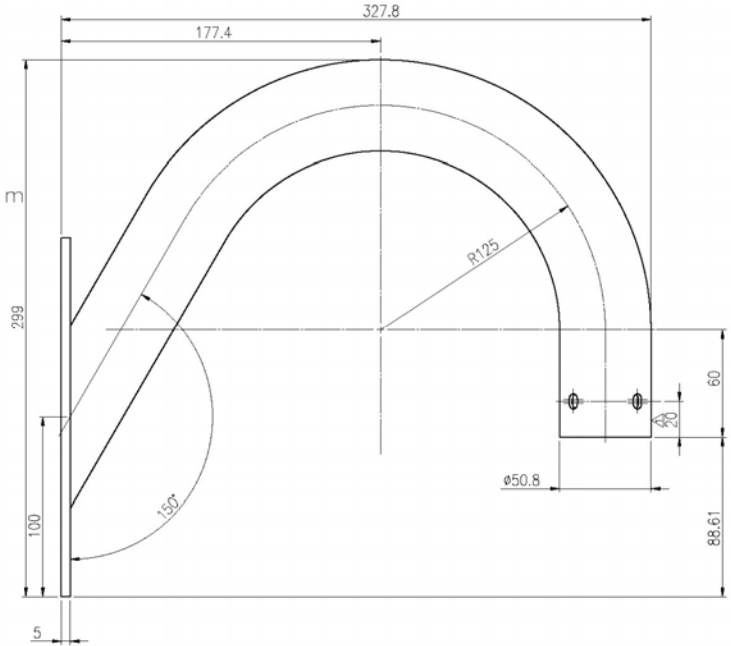

2.5.3 Outdoor Ceiling mount

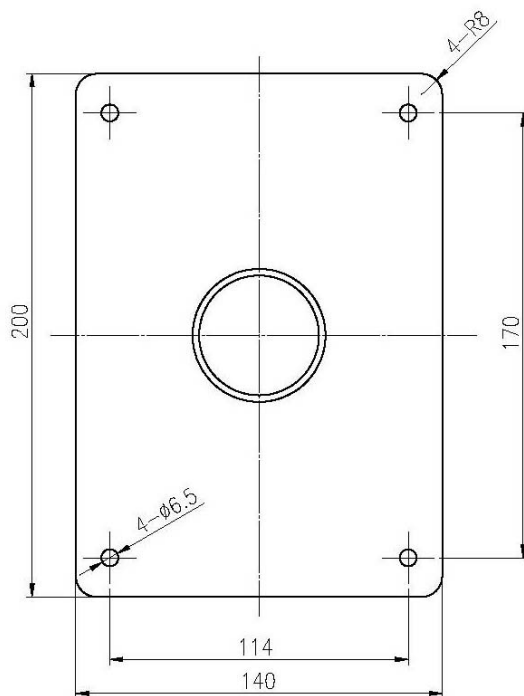
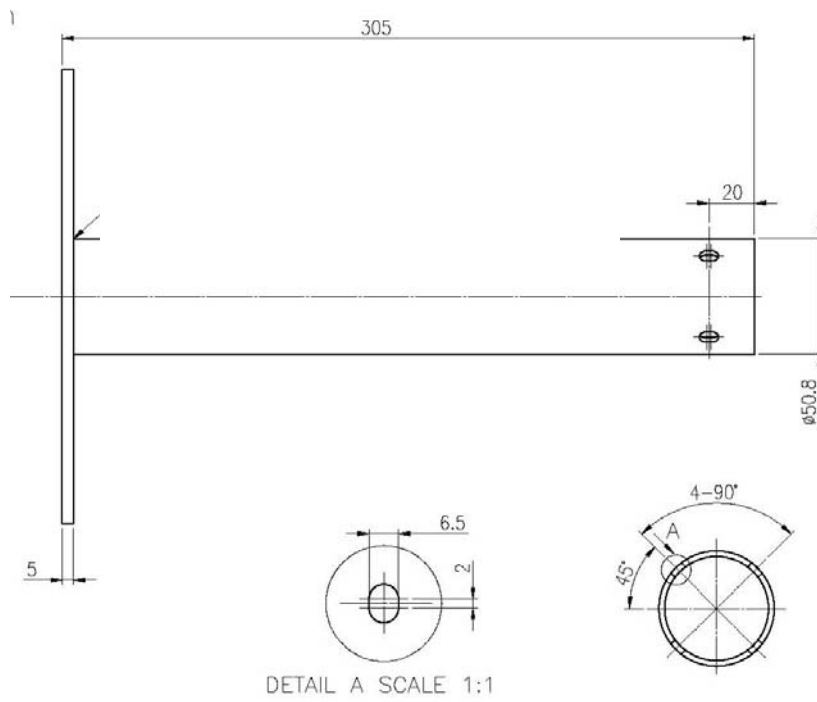

2.5.4 Outdoor Corner mount

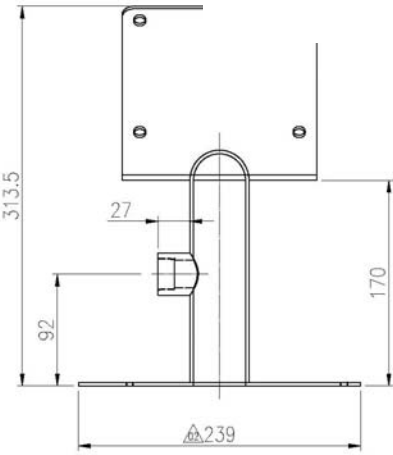
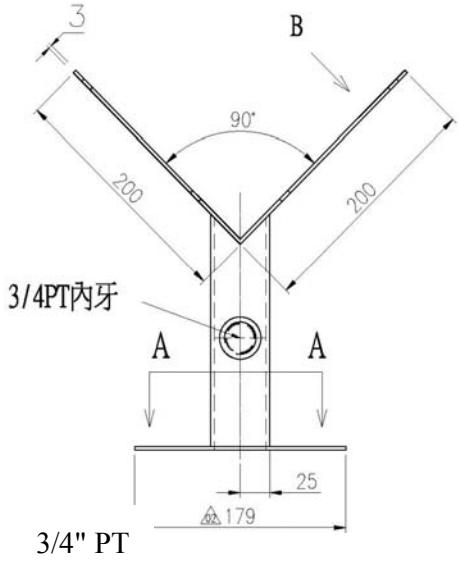
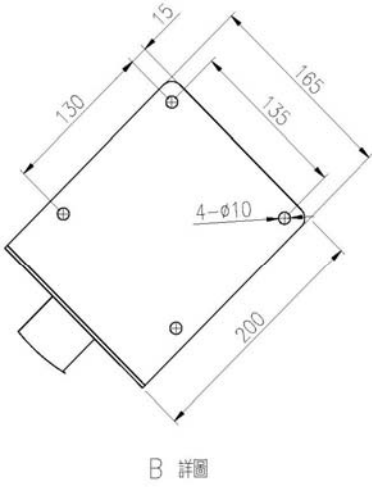
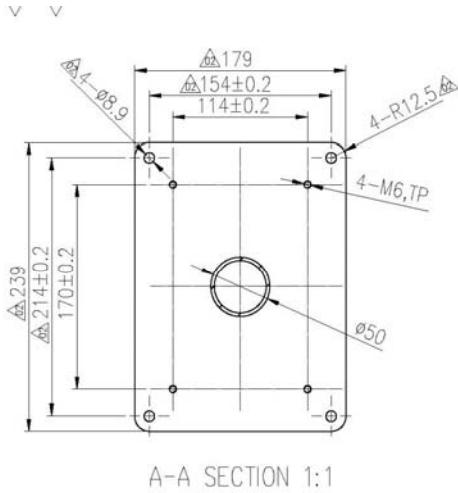

2.5.5 Outdoor Pole mount

These four holes are symmetrical to each

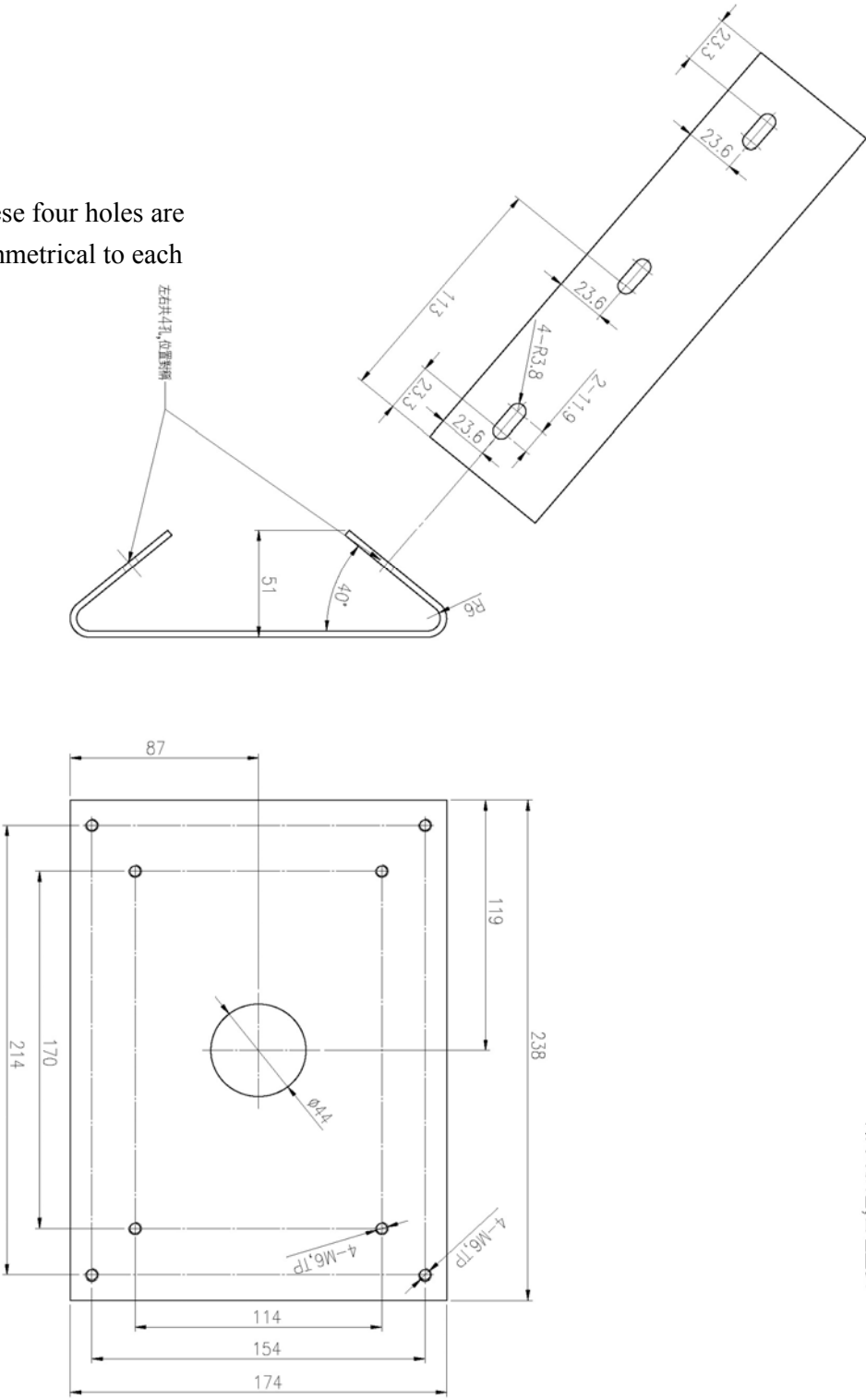

3

Appendix

3.1 Camera ID Sep up

Symbol “○” in the following tables denote setting “ON”

	1	2	3	4	5	6	7	8
1	○							
2		○						
3	○	○						
4			○					
5	○		○					
6		○	○					
7	○	○	○					
8				○				
9	○			○				
10		○		○				
11	○	○		○				
12			○	○				
13	○		○	○				
14		○	○	○				
15	○	○	○	○				
16					○			
17	○				○			
18		○			○			
19	○	○			○			
20			○		○			
21	○		○		○			
22		○	○		○			
23	○	○	○		○			
24				○	○			
25	○			○	○			

	1	2	3	4	5	6	7	8
26		○		○	○			
27	○	○		○	○			
28			○	○	○			
29	○		○	○	○			
30		○	○	○	○			
31	○	○	○	○	○			
32						○		
33	○					○		
34		○				○		
35	○	○				○		
36			○			○		
37	○		○			○		
38		○	○			○		
39	○	○	○			○		
40				○		○		
41	○			○		○		
42		○		○		○		
43	○	○		○		○		
44			○	○		○		
45	○		○	○		○		
46		○	○	○		○		
47	○	○	○	○		○		
48					○	○		
49	○				○	○		
50		○			○	○		

	1	2	3	4	5	6	7	8
51	○	○			○	○		
52			○		○	○		
53	○		○		○	○		
54		○	○		○	○		
55	○	○	○		○	○		
56				○	○	○		
57	○			○	○	○		
58		○		○	○	○		
59	○	○		○	○	○		
60			○	○	○	○		
61	○		○	○	○	○		
62		○	○	○	○	○		
63	○	○	○	○	○	○		
64							○	
65	○						○	
66		○					○	
67	○	○					○	
68			○				○	
69	○		○				○	
70		○	○				○	
71	○	○	○				○	
72				○			○	
73	○			○			○	
74		○		○			○	
75	○	○		○			○	

	1	2	3	4	5	6	7	8
76			○	○			○	
77	○		○	○			○	
78		○	○	○			○	
79	○	○	○	○				
80					○		○	
81	○				○		○	
82		○			○		○	
83	○	○			○		○	
84			○		○		○	
85	○		○		○		○	
86		○	○		○		○	
87	○	○	○		○		○	
88				○	○		○	
89	○			○	○		○	
90		○		○	○		○	
91	○	○		○	○		○	
92			○	○	○		○	
93	○		○	○	○		○	
94		○	○	○	○		○	
95	○	○	○	○	○		○	
96						○	○	
97	○					○	○	
98		○				○	○	
99	○	○				○	○	
100			○			○	○	

	1	2	3	4	5	6	7	8
101	○		○			○	○	
102		○	○			○	○	
103	○	○	○			○	○	
104				○		○	○	
105	○			○		○	○	
106		○		○		○	○	
107	○	○		○		○	○	
108			○	○		○	○	
109	○		○	○		○	○	
110		○	○	○		○	○	
111	○	○	○	○		○	○	
112					○	○	○	
113	○				○	○	○	
114		○			○	○	○	
115	○	○			○	○	○	
116			○		○	○	○	
117	○		○		○	○	○	
118		○	○		○	○	○	
119	○	○	○		○	○	○	
120				○	○	○	○	
121	○			○	○	○	○	
122		○		○	○	○	○	
123	○	○		○	○	○	○	
124			○	○	○	○	○	
125	○		○	○	○	○	○	

	1	2	3	4	5	6	7	8
126		○	○	○	○	○	○	
127	○	○	○	○	○	○	○	
128								○
129	○							○
130		○						○
131	○	○						○
132			○					○
133	○		○					○
134		○	○					○
135	○	○	○					○
136				○				○
137	○			○				○
138		○		○				○
139	○	○		○				○
140			○	○				○
141	○		○	○				○
142		○	○	○				○
143	○	○	○	○				○
144					○			○
145	○				○			○
146		○			○			○
147	○	○			○			○
148			○		○			○
149	○		○		○			○
150		○	○		○			○

	1	2	3	4	5	6	7	8
151	○	○	○		○			○
152				○	○			○
153	○			○	○			○
154		○		○	○			○
155	○	○		○	○			○
156			○	○	○			○
157	○		○	○	○			○
158		○	○	○	○			○
159	○	○	○	○	○			○
160						○		○
161	○					○		○
162		○				○		○
163	○	○				○		○
164			○			○		○
165	○		○			○		○
166		○	○			○		○
167	○	○	○			○		○
168				○		○		○
169	○			○		○		○
170		○		○		○		○
171	○	○		○		○		○
172			○	○		○		○
173	○		○	○		○		○
174		○	○	○		○		○
175	○	○	○	○		○		○

	1	2	3	4	5	6	7	8
176					○	○		○
177	○				○	○		○
178		○			○	○		○
179	○	○			○	○		○
180			○		○	○		○
181	○		○		○	○		○
182		○	○		○	○		○
183	○	○	○		○	○		○
184				○	○	○		○
185	○			○	○	○		○
186		○		○	○	○		○
187	○	○		○	○	○		○
188			○	○	○	○		○
189	○		○	○	○	○		○
190		○	○	○	○	○		○
191	○	○	○	○	○	○		○
192							○	○
193	○						○	○
194		○					○	○
195	○	○					○	○
196			○				○	○
197	○		○				○	○
198		○	○				○	○
199	○	○	○				○	○
200				○			○	○

	1	2	3	4	5	6	7	8
201	○			○			○	○
202		○		○			○	○
203	○	○		○			○	○
204			○	○			○	○
205	○		○	○			○	○
206		○	○	○			○	○
207	○	○	○	○			○	○
208					○		○	○
209	○				○		○	○
210		○			○		○	○
211	○	○			○		○	○
212			○		○		○	○
213	○		○		○		○	○
214		○	○		○		○	○
215	○	○	○		○		○	○
216				○	○		○	○
217	○			○	○		○	○
218		○		○	○		○	○
219	○	○		○	○		○	○
220			○	○	○		○	○
221	○		○	○	○		○	○
222		○	○	○	○		○	○
223	○	○	○	○	○		○	○
224						○	○	○
225	○					○	○	○

	1	2	3	4	5	6	7	8
226		○				○	○	○
227	○	○				○	○	○
228			○			○	○	○
229	○		○			○	○	○
230		○	○			○	○	○
231	○	○	○			○	○	○
232				○		○	○	○
233	○			○		○	○	○
234		○		○		○	○	○
235	○	○		○		○	○	○
236			○	○		○	○	○
237	○		○	○		○	○	○
238		○	○	○		○	○	○
239	○	○	○	○		○	○	○
240					○	○	○	○
241	○				○	○	○	○
242		○			○	○	○	○
243	○	○			○	○	○	○
244			○		○	○	○	○
245	○		○		○	○	○	○
246		○	○		○	○	○	○
247	○	○	○		○	○	○	○
248				○	○	○	○	○
249	○			○	○	○	○	○
250		○		○	○	○	○	○